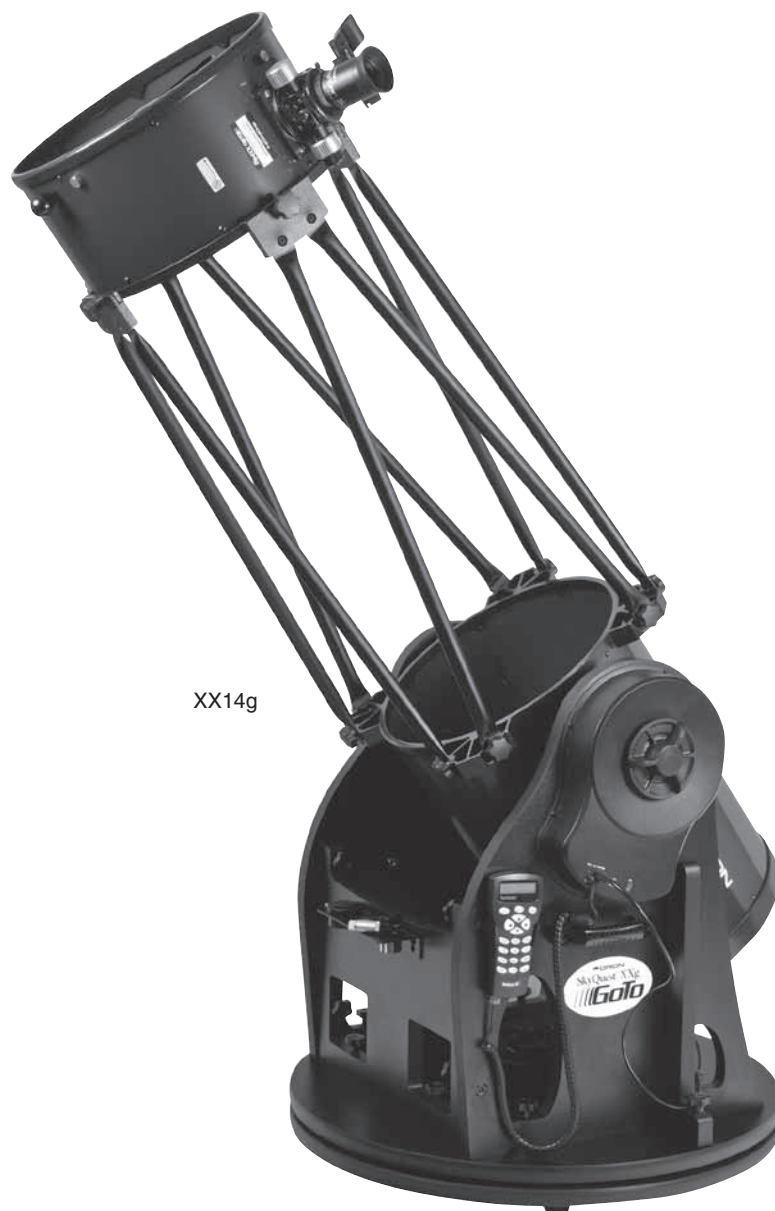


# Orion® SkyQuest™ XXg GoTo Truss Tube Dobsonians

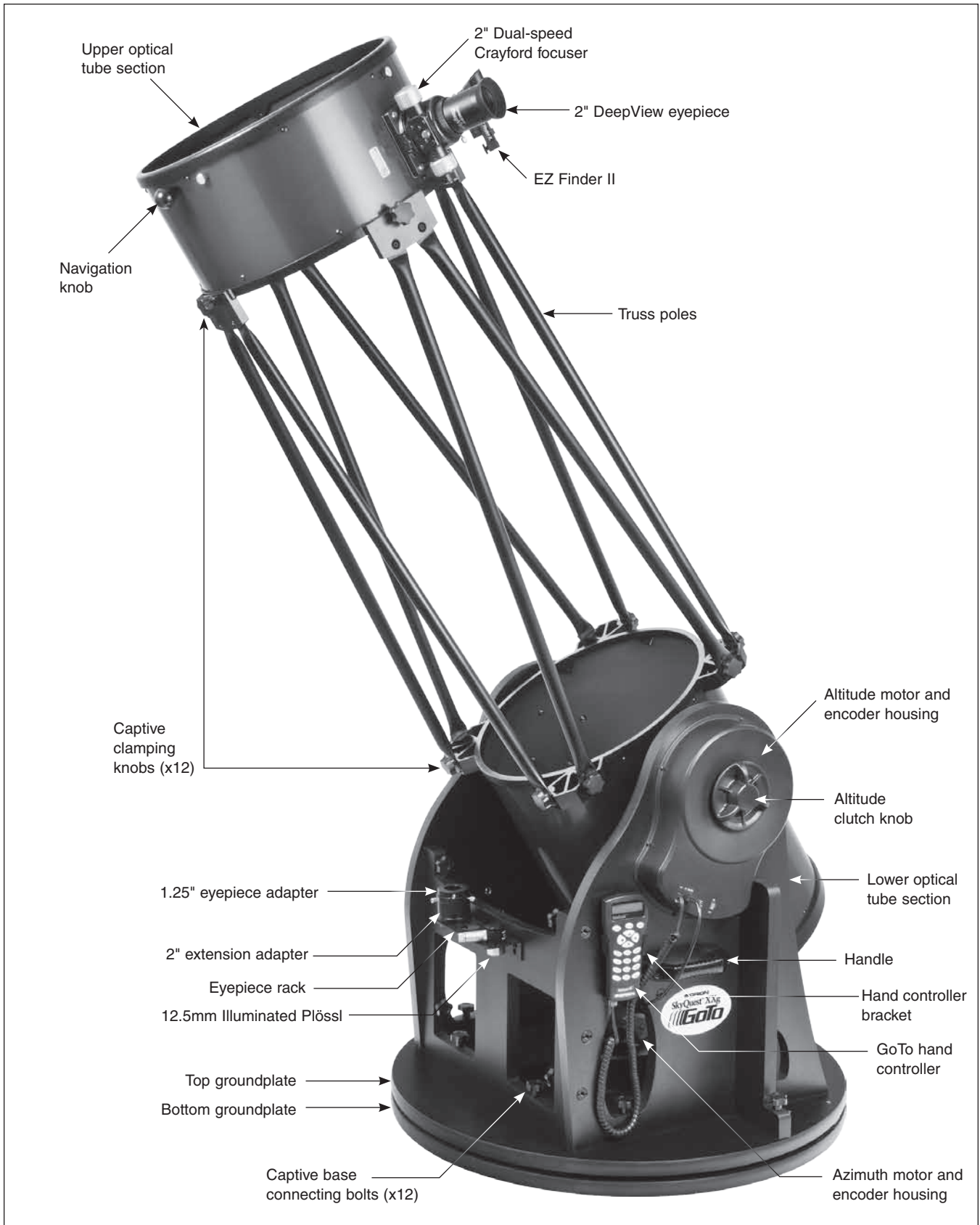
#10148 XX12g, #8964 XX14g, #8968 XX16g



XX14g

 **ORION**  
TELESCOPES & BINOCULARS  
*Providing Exceptional Consumer Optical Products Since 1975*

*Customer Support:*  
[www.OrionTelescopes.com/contactus](http://www.OrionTelescopes.com/contactus)  
*Corporate Offices:*  
89 Hangar Way, Watsonville CA 95076 - USA



**Figure 1.** Overview of SkyQuest XXg Dobsonian (16" shown)

---

*Congratulations on your purchase of an Orion SkyQuest XXg GoTo Dobsonian.* These revolutionary Dobs combine large-aperture optical performance with state-of-the-art computerized GoTo pointing capability. Moreover, these big telescopes were designed by Orion to be remarkably transportable – both their base and optical tube break down into easily manageable components that can fit into any standard size vehicle. Setup for an observing session takes just minutes, and the views are spectacular! We know you will enjoy many years of rewarding observations with your SkyQuest XXg GoTo Truss Dobsonian.

Please read these instructions thoroughly before beginning assembly and subsequent use of the telescope.

## Table of Contents

1. Unpacking . . . . .	3
2. Assembly . . . . .	7
3. The GoTo Hand Controller . . . . .	15
4. Collimating the Optical System . . . . .	16
5. Using Your Telescope . . . . .	18
6. Specifications . . . . .	22

**WARNING:** *Never look directly at the Sun through your telescope or its finder scope – even for an instant – without a professionally made solar filter that completely covers the front of the instrument, or permanent eye damage could result. Young children should use this telescope only with adult supervision.*

## 1. Unpacking

The SkyQuest XX12g is packed in three boxes, one containing the optical tube assembly (OTA), truss poles, and accessories; a second containing the unassembled Dobsonian base; and third containing the primary mirror and mirror cell. The XX14g ships in four boxes, with the truss poles and counterweights contained in a separate box. The XX16g is packaged in five boxes, with the base components divided into two separate boxes to keep the weight and size of the individual boxes more manageable.

Before beginning assembly, unpack each box and confirm that all of the parts in the Parts List below are present. The parts are listed by the box they should arrive in, but some of the parts may be in different boxes than indicated below. Be sure to check all boxes carefully, as some parts are small. If anything appears to be missing or broken, immediately call Orion Customer Support (800-676-1343) or email [support@telescope.com](mailto:support@telescope.com) for assistance.

# Parts List

## Box #1: Optical Tube Assembly and Accessories (Figure 2)

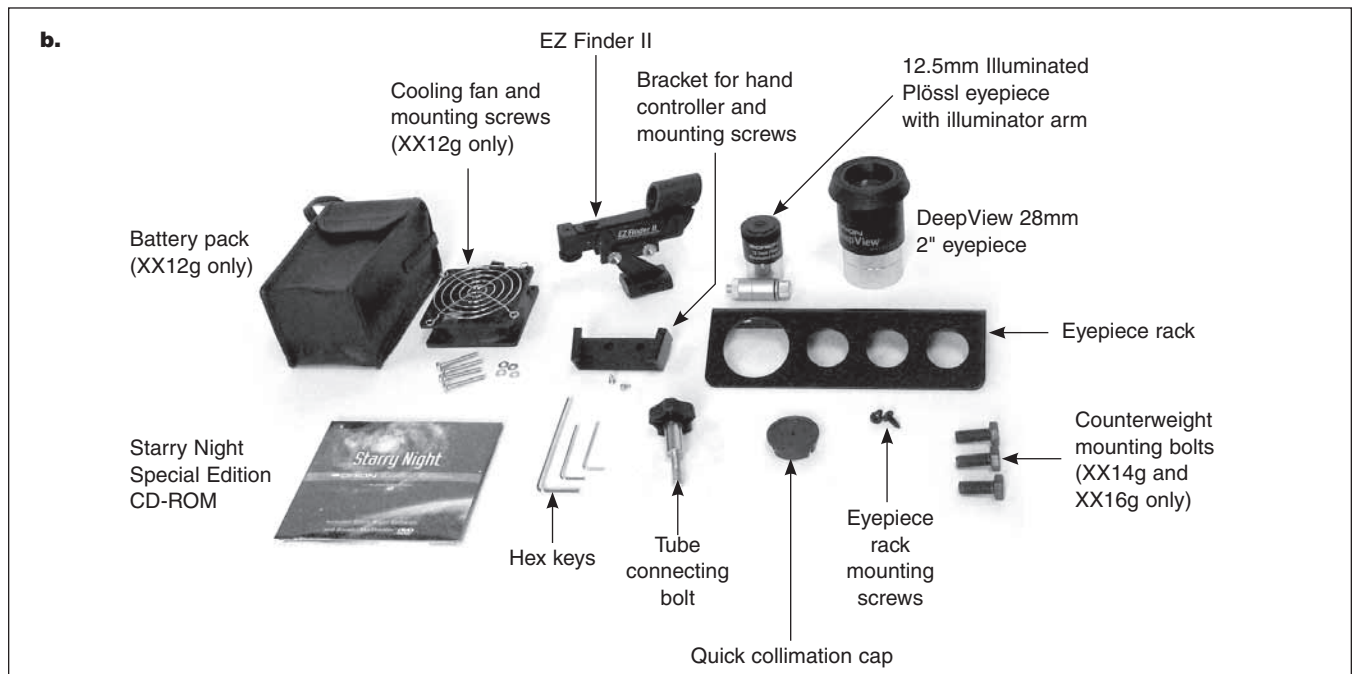
### Qty. Description

- 1 Lower optical tube section
- 1 Upper optical tube section
- 2 Optical tube dust covers (one for each tube section)
- 4 Truss pole pairs (XX12g only)
- 1 DeepView 28mm eyepiece, 2"
- 1 Eyepiece extension adapter, 2" (not shown)
- 1 Illuminated 12.5mm Plössl eyepiece, 1.25"
- 1 EZ Finder (with bracket)
- 1 Collimation cap
- 1 Eyepiece rack
- 2 Eyepiece rack wood screws (20mm long, color black)
- 2 Hex keys (2mm, 2.5mm)
- 1 Tube connecting knob
- 1 SynScan AZ Hand controller
- 1 Hand controller cable (coiled)

- 1 Azimuth motor connection cable
- 1 RS-232 computer interface cable
- 1 Hand controller bracket (with 2 mounting screws)
- 3 Counterweight mounting bolts (XX14g, XX16g)
- 1 Cooling accelerator fan with battery holder (XX12g only)
- 1 Instruction manual (not shown)
- 1 Starry Night CD-ROM



**Figure 2.** Contents of the optical tube box. **a)** The larger components. **b)** Accessories and hardware.



**Box #2: Primary Mirror and Cell** (Figure 3)

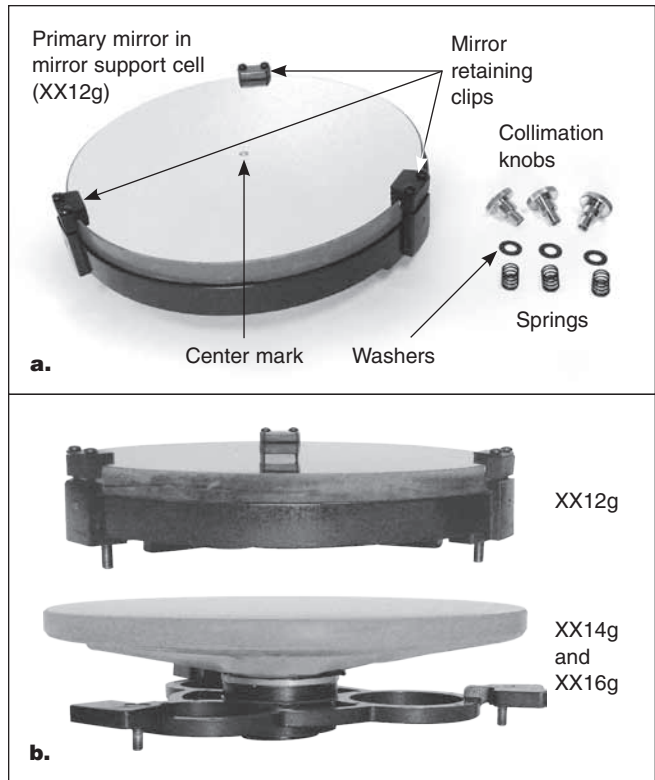
**Qty. Description**

- 1 Parabolic primary mirror (XX12g, flat back; XX14g and XX16g, convex back)
- 1 Mirror support cell
- 3 Collimation knobs
- 3 Nylon washers (3/4" outer diameter)
- 3 Springs

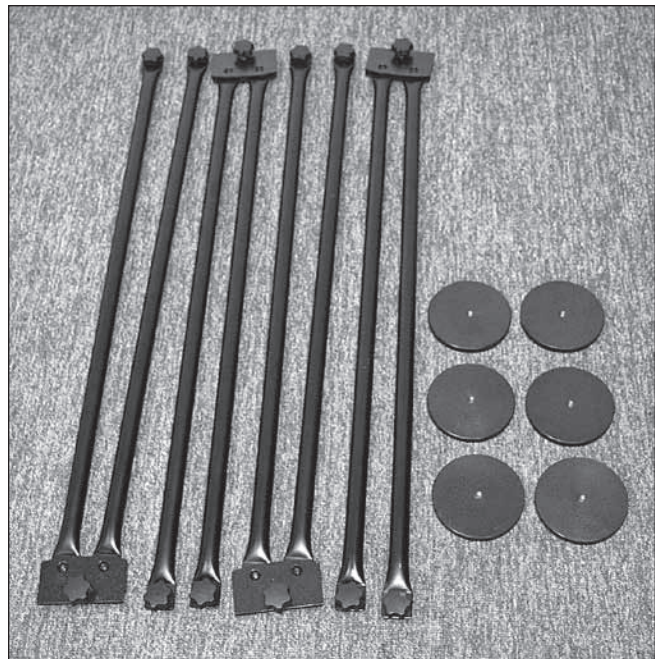
**Box #3: Truss Pole Assemblies and Counterweights (XX14g and XX16g)** (Figure 4)

**Qty. Description**

- 4 Truss pole pairs
- 6 Counterweights, 2.2 lbs. each (XXX14g only)
- 9 Counterweights, 2.2 lbs. each (XXX16g only)



**Figure 3.** Contents of the primary mirror box. **a)** The primary mirror, mirror cell, and collimation hardware for the XX12g. **b)** The primary mirrors and mirror support cells for the XX12g (top) and XX14g/XX16g are quite different.



**Figure 4.** Contents of the truss pole and counterweight box. (The XX16g contains nine counterweights.) For the XX12g, the truss poles are included in the optical tube box, and there are no counterweights.



**Box #4: Dobsonian Base** (Figure 5)

**Qty. Description**

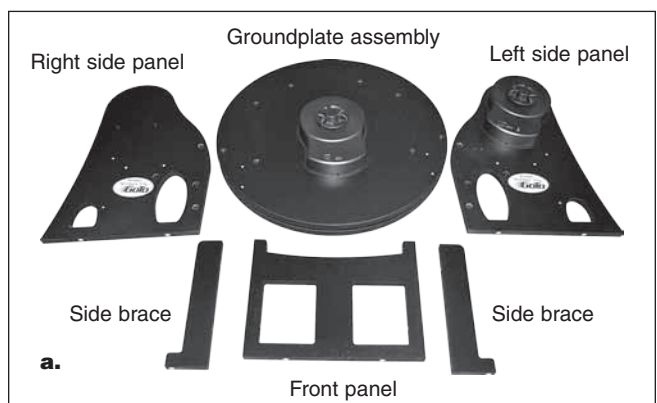
- 1 Left side panel (with altitude motor and encoders pre-installed)
- 1 Right side panel
- 1 Front panel
- 2 Side braces
- 1 Groundplate assembly (with azimuth motor and encoders pre-installed) This is contained in a separate box (Box #5) for the XX16g.
- 6 Base assembly wood screws (coarse thread, 47mm long)
- 12 Base connecting bolts with hand knobs
- 12 Rubber retaining washers
- 12 Spacers for connecting bolts
- 1 Insertion tube for rubber retaining washers (~3" long)

- 2 Carrying handles
- 4 Handle mounting bolts (socket head cap screws, 25mm long)
- 3 Hex keys (size 2mm, 4mm, 6mm)
- 3 Plastic feet (XX12g only; feet are pre-installed on XX14g and XX16g)
- 3 Feet wood screws (1" long; XX12g only)

**Box #5: Dobsonian Base (XX16g only)**

**Qty. Description**

- 1 Groundplate assembly (with azimuth motor and encoders pre-installed)



**Figure 5.** Contents of the base box(es). **a)** The larger components, **b)** Hand controller, cables, and other hardware.



## 2. Assembly

Now that you have unpacked the boxes and familiarized yourself with all the parts, it is time to begin assembly.

### Initial Assembly of the GoTo Dobsonian Base

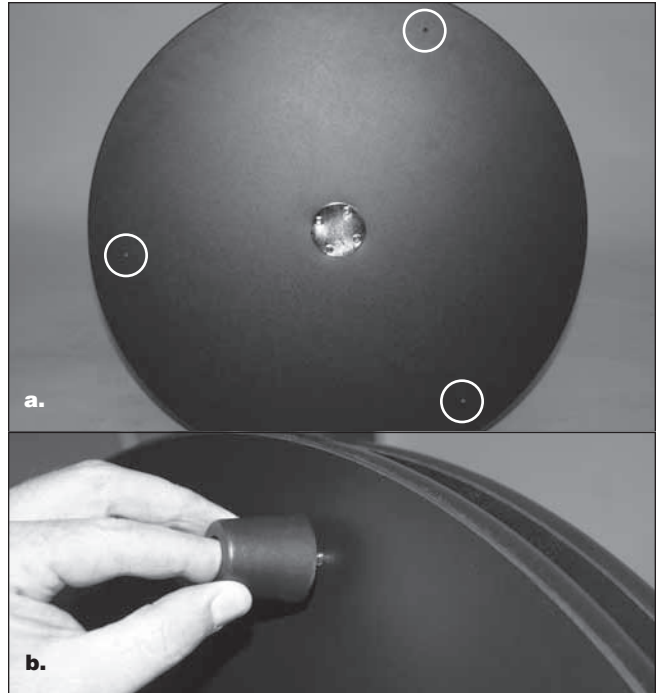
The GoTo bases of the SkyQuest XXg Dobs are shipped partially assembled for your convenience. All the motors, optical encoders, and gears are pre-installed at the factory. The two round groundplates are preassembled and should not be taken apart.

When fully assembled, the SkyQuest XXg GoTo Truss Tube Dobsonians are big telescopes. But we designed them to break down into easily manageable components, none of which is too big or too heavy for a reasonably fit individual to lift and carry (but for the XX16g a helper would be great!). In fact, both the base and the optical tube can be quickly disassembled into smaller components for transport and/or storage, then reassembled – all without tools! We'll get to the tube later, but for the base you'll see that it has four main components: the groundplate assembly (top and bottom groundplates and installed azimuth motor housing), the left side panel with installed altitude motor housing, the right side panel, and the front panel.

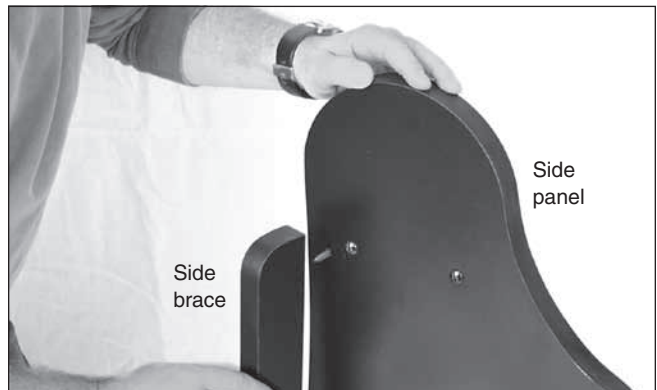
For the initial assembly of the base, you will need a Philips screwdriver.

1. To install the feet (XX12g only; feet are pre-installed at the factory on the XX14g and XX16g), turn the groundplate assembly upside-down and gently rest it on the azimuth motor housing on a clean, flat surface. Carpet is good, or you may want to place a cloth under the azimuth motor housing to avoid scratching it. Locate the three starter holes on the perimeter of the bottom groundplate (**Figure 6a**). Insert the screws through the feet and thread them into the predrilled starter holes (**Figure 6b**) with a Phillips screwdriver until tight.
2. Connect the side braces to the side panels using three base assembly screws for each panel (**Figure 7**). The brace should be attached to the outside surface of the side panel – the outside of the left side panel has the altitude motor housing attached. The screws go through the holes in the side panels and thread into the starter holes in the side braces. Use the included 4mm hex key to firmly tighten the screws, but be careful not to strip the holes by over-tightening!
3. Now you will install the captive connecting bolts, each of which is already fitted with a black hand knob. There are 12 connecting bolts altogether; refer to **Figure 8** for locations. Start with the front panel, which has through holes for six connecting bolts.

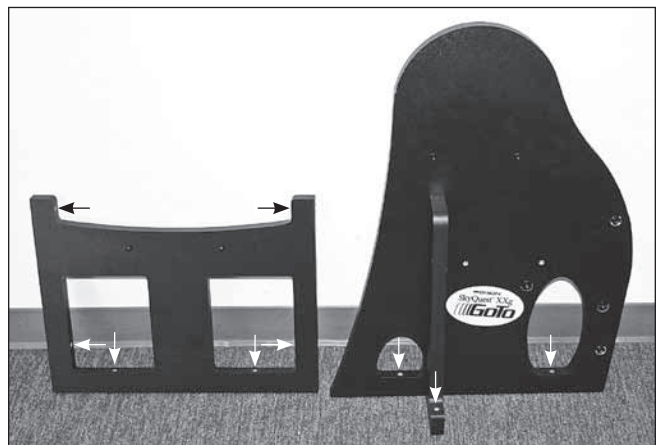
First, slide a spacer onto a collecting bolt. Then insert the connecting bolt into the through hole, in the direction indicated in **Figure 8**. Holding the knob with one hand, use your other hand to press a rubber washer over the threaded (protruding) end of the bolt. It will be a tight fit; you may have to work the washer a bit to get it on. Push the washer up on the bolt as far as you can with your



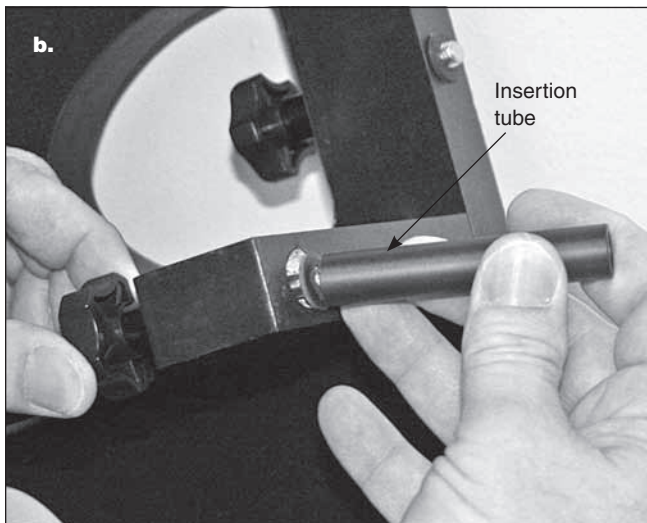
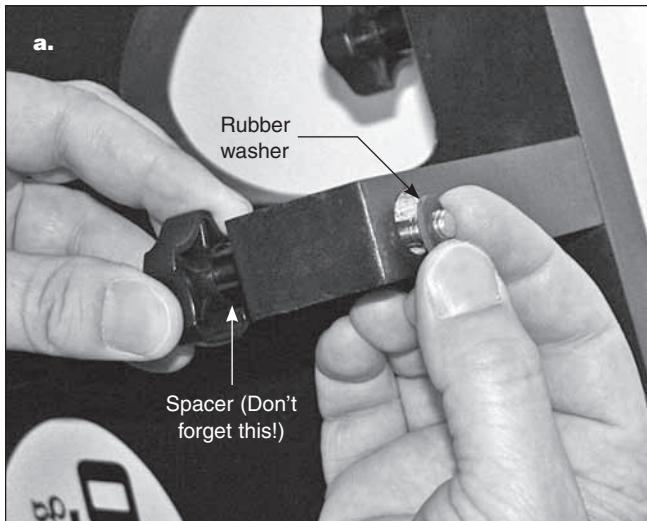
**Figure 6. a)** Starter holes for feet on bottom baseplate. **b)** Attaching the base feet.



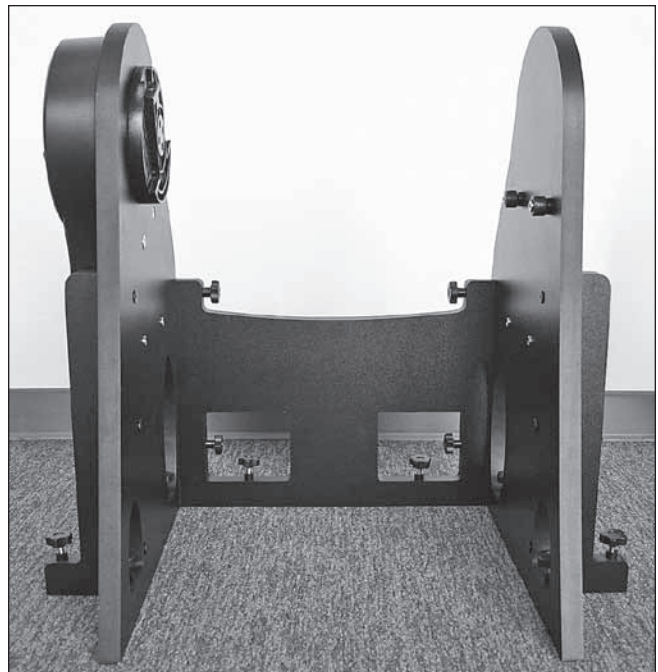
**Figure 7.** Attach a side brace to the outside of each side panel using three base assembly wood screws and the 4mm hex key.



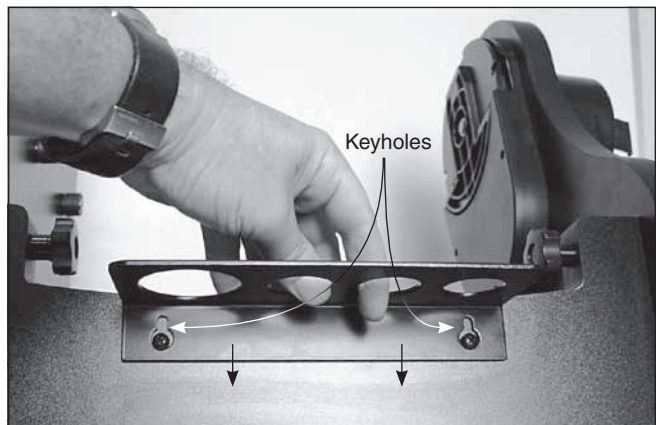
**Figure 8.** Locations for connecting bolts in the front and side panels (one side panel not shown). Connecting bolts should be inserted in the predrilled holes in the direction indicated by the arrows.



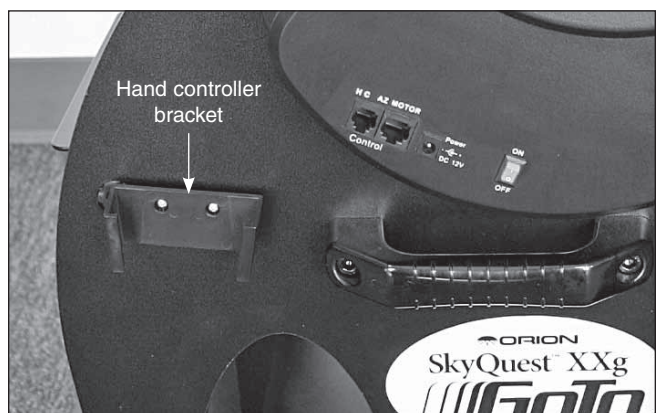
**Figure 9.** **a)** Place a rubber washer on the threaded end of the connecting bolt and push it on as far as you can with your fingers. **b)** Then use the included insertion tube to push the washer past the threads and up into the counterbored hole in the wood. **c)** The recessed washer will keep the bolt captive in the hole.



**Figure 10.** The completed side panel and front panel assembly.



**Figure 11.** Place the large opening of the “keyhole” slots in the eyepiece rack over the mounting screw heads, then push the rack downward. To do this, leave the screw heads about 1/8” out from the panel. After the rack is installed, you can tighten the screws to secure it in place.



**Figure 12.** Find the two pilot holes and attach the hand controller bracket – but don’t overtighten the screws!





**Figure 13.** The altitude motor housing has jacks for the hand controller (HC) cable, azimuth motor connection cable, and power cable as well as an ON/OFF switch.

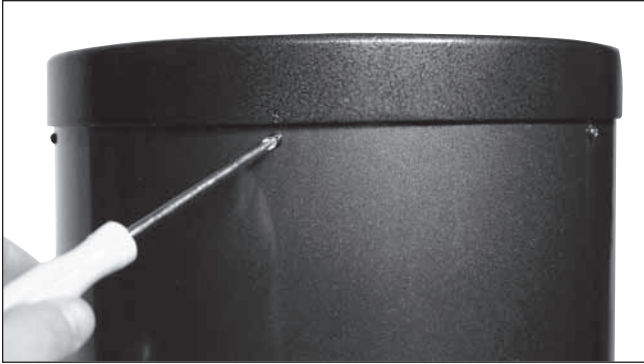
- fingers (**Figure 9a**). Then place the insertion tube on the bolt (**Figure 9b**) and use it to push the washer farther up on the bolt, into the counterbored hole in the wood (**Figure 9c**). The washer will keep the bolt captive when it is fully disengaged from the mating part of the base. Repeat this procedure for the other five connecting bolts to be installed in the front panel, and for the six additional connecting bolts that attach the side panels and side braces to the top groundplate.
- Now attach the front brace to the two side panels with the four appropriate captive connecting bolts. Use the hand knob to screw each bolt into the threaded metal receptacle recessed in the side panel. The side panels should be oriented so the side braces are facing outward. The front panel should be oriented so that the two pilot holes for the eyepiece rack face outward. Do not completely tighten the connecting bolts yet. The completed assembly should look like **Figure 10**.
  - Place the assembled side panel/front panel structure on the top groundplate, aligning the protruding connecting bolts with the threaded inserts in the groundplate. Turn the connecting bolt hand knobs to fasten the side panel/front panel structure to the groundplate. Firmly tighten all 12 connecting bolts installed in steps 3 and 4. To avoid stripping the threads, do not overtighten.

- Attach a handle on each of the two side panels. Insert a large socket head cap screw through the holes in the handle and into the predrilled hole in the side panel. The hole has a flanged threaded metal insert in it. Use the 6mm hex key to thread the screw into the insert until tight. Refer to **Figure 1** for handle placement.
- The aluminum eyepiece rack holds three 1.25" eyepieces and one 2" eyepiece in a convenient place on the base, within easy reach while you are observing. To attach the eyepiece rack, locate the two small pilot holes on the front panel. Thread the small Phillips-head screws into the holes until the screw head is about 1/8" from the panel's surface. Now place the wide part of the "keyhole" on the eyepiece rack over the screw heads and slide it downward until it stops (**Figure 11**). Tighten the screws to secure the rack in place.
- The XXg base includes a bracket that holds the hand controller when it's not in use. The bracket mounts on the left side panel adjacent to the altitude motor housing (**Figure 12**). Locate the two small pilot holes and attach the bracket using the small screws included with the bracket until just barely tight. Do not over-tighten these screws or you will strip the holes!
- Now install the azimuth motor connection cable. It is a flat cable that has an 8-pin RJ-45 plug on both ends. Plug one end into the jack on the azimuth motor housing on the top groundplate; plug the other end into the jack labeled AZ MOTOR on the altitude motor housing (**Figure 13**).
- Finally, connect the GoTo hand controller. Plug the wide RJ-45 connector on the coiled hand controller cable into the corresponding port on the hand controller. Plug the smaller RJ-12 connector into the port labeled HC on the altitude motor housing. Refer to the *SynScan GoTo Hand Controller manual*.

### Initial Assembly of the Optical Tube

The primary mirror is shipped in its metal support cell separately from the optical tube, to prevent possible damage to both the mirror and the optical tube. Once the primary mirror is installed, there will be no need to remove it except if cleaning is necessary (see "Care & Maintenance"). First, the mirror will be installed in the lower tube section, then the truss poles and upper tube section will be attached.

The primary mirror of the XX12g has the typical flat back side, whereas the thinner primaries of the XX14g and XX16g have a "conical," or convex back with raised "ribs" radiating from the center for added strength. The reduced-mass design of these larger mirrors allows more-efficient equilibration to outdoor ambient temperature. All the primary mirrors have a small adhesive ring placed in the exact center (**Figure 3a**); it aids in achieving a precise collimation, which will be covered later. The ring, which has no effect on the image rendered by the telescope, should NOT be removed.



**Figure 14.** To remove the rear end ring, unthread the screws that connect it to the tube.

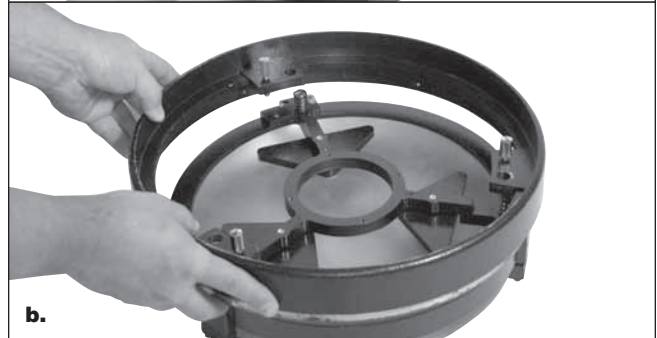
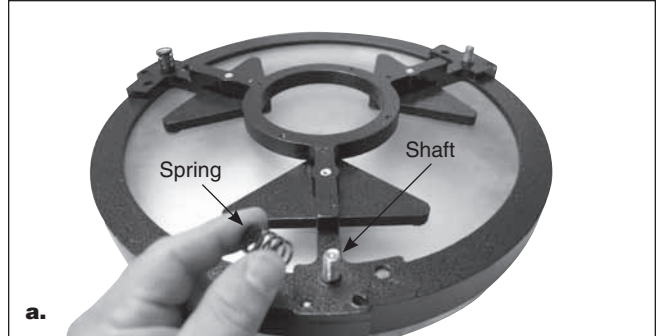


**Figure 15.** Thread the three hex-head counterweight mounting bolts (XX14g and XX16g only) into the holes in the counterweight support plates as shown. Tighten using an adjustable or 16mm crescent wrench.

1. To install the mirror cell in the optical tube, the rear end ring attached to the lower tube section must first be removed. This is done by unthreading and removing the Phillips-head screws that attach the end ring to the tube (**Figure 14**), and then pulling the end ring off of the tube.

**Warning:** *Once the rear end ring is removed from the tube, the raw edge of the tube itself will be exposed. Be careful not to cut or otherwise hurt yourself on the tube's edge. Also, be careful not to pinch your fingers between cell and tube when re-attaching the assembled mirror cell!*

2. Next, for the XX14g and XX16g, thread the three counterweight mounting bolts into their respective holes in the rear end ring, as shown in **Figure 15**. Use an adjustable wrench or a 16mm crescent wrench to tighten the bolts. Do not install the counterweights yet.
3. Next, assemble the telescope's rear end ring to the primary mirror cell. Find a clean, flat surface, and turn the mirror cell over so that the mirror is facing downward. For the XX14g and XX16g, we recommend placing a soft towel on a flat surface and placing the mirror face down on the towel, because the aluminized outer edge of the mirror *will* contact the surface. With the XX12g mirror on the other hand, the aluminized mirror itself will not

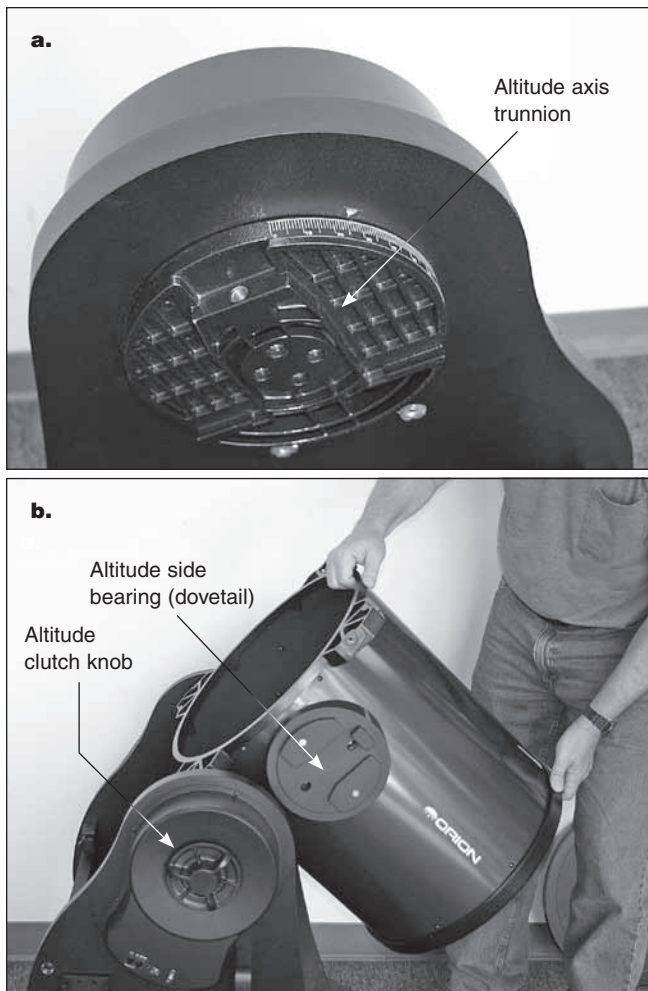


**Figure 16.** Shown for XX12g. **a)** Place the three springs on the exposed threaded shafts of the mirror cell. **b)** Lower the rear end ring onto the mirror cell so that the threaded shafts pass through the end ring, and the end ring rests on the springs. **c)** Thread the collimation knobs, with nylon washers attached, through the rear end ring and onto the threaded shafts. Make sure the knobs have at least three full turns of engagement on the shafts.



**Figure 17.** Locate the area of tube that is bulging out and preventing the end ring from fully seating. Press on this bulge to allow the mirror cell to seat properly on the tube. Be careful not to pinch fingers!





**Figure 18. a)** Altitude axis trunnion on left side panel. **b)** Grasp both ends of the lower tube section to lift it, then lower it into the base, sliding the dovetail slot in the tube's left altitude bearing into the mating part of the trunnion.

make contact with the surface; only the mirror retaining clips will. Place the three springs onto the three exposed threaded shafts (**Figure 16a**). (The XX12g mirror is shown, but the procedure is similar for the XX14g and XX16g.) Lower the end ring onto the mirror cell so the threaded shafts pass through it, and the end ring rests on the springs (**16b**). Add a nylon washer to each collimation knob and thread the collimation knobs through the end ring and onto the threaded shafts (**16c**). Make sure the knobs have at least three full turns of engagement on the shafts. The mirror cell is now almost ready to be installed onto the lower tube section.

4. Check to make sure that the three mirror retaining clips are properly tensioned (XX12g only, **Figure 3a**). If they are too tight, the pinching of the mirror's edge will distort the images you see through the telescope. But if they are too loose, the mirror could shift or even fall out if it is tilted severely. With the mirror in its cell facing up, use a

Phillips screwdriver to loosen the two screws on one of the clips until you can easily move the small metal plate underneath the screw heads. Then gradually tighten both screws *just* until the metal plate is no longer loose – no tighter! Repeat this with the other two retaining clips. Now the clips are properly tensioned.

5. Assembling the end ring (and mirror assembly) back onto the tube can be a bit tricky. This is because the large diameter and thin metal of the tube will cause the tube to become somewhat out of round once the end ring is removed. To assemble the rear end ring (with mirror and mirror cell now connected) to the tube, stand the lower section of the tube up vertically so the raw edge of the tube is up. Line up the threaded holes in the edge of the end ring with the holes in the end of the tube. Then, lower the entire assembly onto the tube. (Be careful to avoid finger pinching during this step!) There may be a bulge in the perimeter of the tube that prevents the end ring from fully seating onto the tube (**Figure 17**). Press against this bulge, and the entire mirror cell assembly should seat onto the tube. Now, replace the Phillips screws that fasten the rear end ring to the tube.

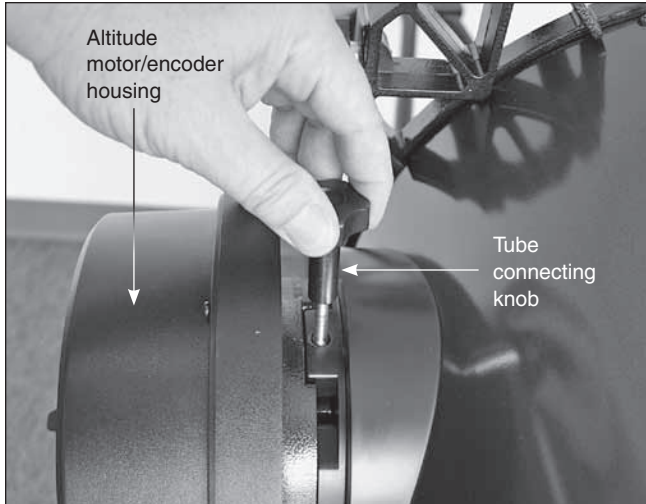
Before assembling the rest of the optical tube, you should consider how you want to mount the optical tube on the base. We recommend mounting the lower tube section onto the base first, THEN adding the counterweights, then the truss poles and upper tube section. Alternatively, you could complete the assembly of the entire optical tube first, then hoist the whole thing onto the base. But for that we strongly recommend getting a second person to help with the lifting – at least for the XX14g and XX16g. For these instructions, we will outline the procedure for installing the lower tube section on the mount first, then building the rest of the OTA from there.

### Mounting the Lower Tube Section (Only) on the Base

1. Loosen the altitude clutch knob slightly so the altitude trunnion can rotate with relatively little resistance.

**Note: To keep the bottom tube section as light as possible for lifting during installation, do not install the counterweights until after the tube is installed on the base (see step 4 below).**

2. The left altitude side bearing on the optical tube has a dovetail slot that slides onto the altitude axis trunnion on the inside of the left side panel (**Figure 18a**). We recommend orienting the trunnion such that the threaded hole for the tube connecting knob is at about a 45-degree angle from horizontal. If the altitude trunnion is oriented differently, you'll have to adjust the angle of the telescope tube accordingly to mount it. Grasp the tube section as shown in **Figure 18b** and lift it. Slide the tube's dovetail altitude bearing into the mating receptacle of the altitude trunnion on the base. Once seated in the base, the tube will freely rotate to a vertical position due to its bottom-heavy imbalance. Maintain your grip on the tube and gently guide it to the resting, vertical position.

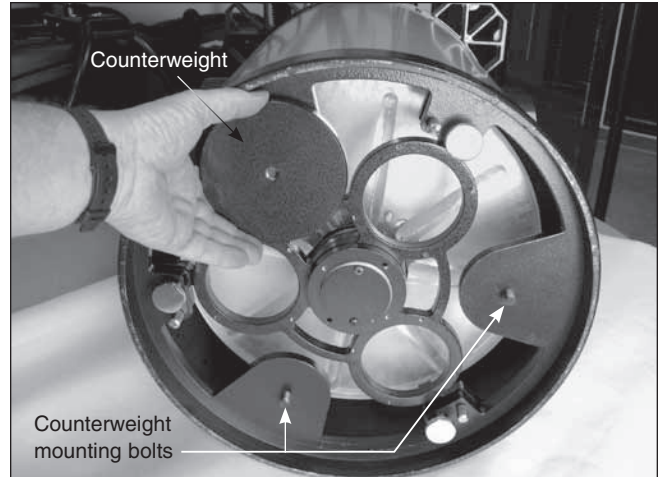


**Figure 19.** Secure the tube to the base with the tube connecting knob.

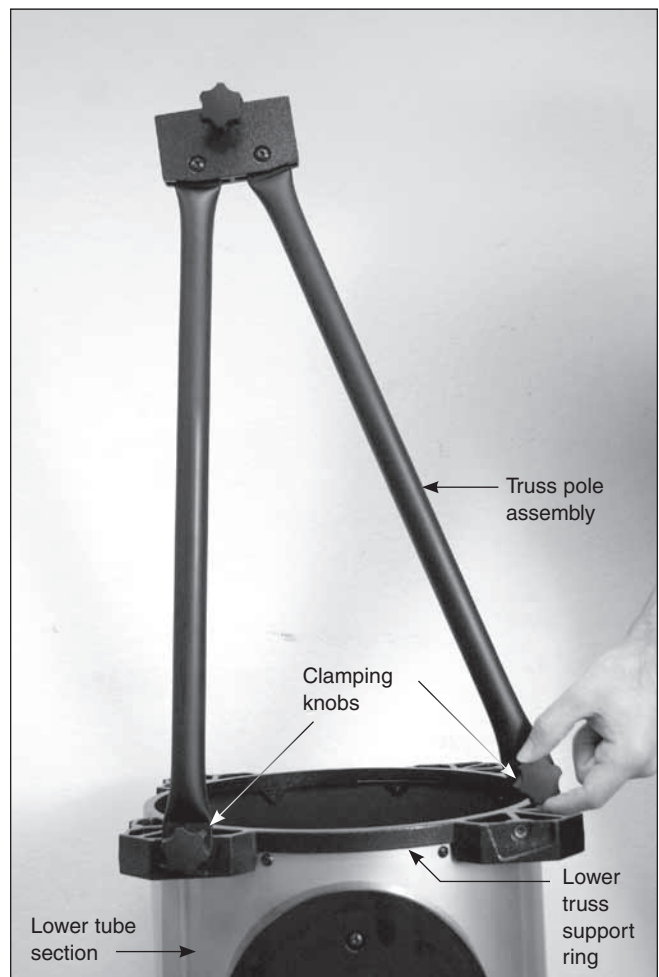
3. Now insert and tighten the tube connecting knob to secure the tube in place (**Figure 19**).
4. For the XX14g and XX16g, before assembling the rest of the optical tube, it is recommended that you install the counterweights on the rear cell so that the tube, when assembled, will be properly balanced rather than front-heavy. (The XX12g does not utilize counterweights.) Without counterweights, the fully assembled tube could swing forward rapidly, possibly damaging the tube and mirrors.

There are six counterweight disks for the XX14g and nine for the XX16g, each weighing 2.2 lbs. For the XX14g, two counterweights are to be threaded onto each bolt, while for the XX16g three counterweights should be installed on each bolt (**Figure 20**). Tilt the lower tube section as needed to access the counterweight mounting bolts on the rear cell, and thread the counterweights onto each of the three mounting bolts. Spin them clockwise until they stop.

5. Now, attach the four truss pole assemblies to the lower tube section. Connect the eight captive clamping knobs on the ends of the pole assemblies to the lower truss sup-

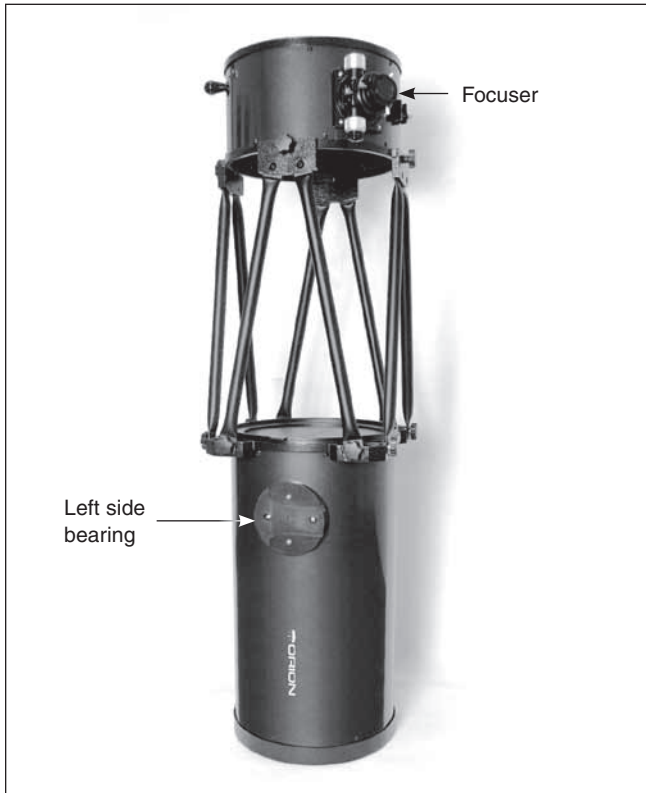


**Figure 20.** Installing counterweights (XX14g and XX16g only). Thread two (for XX14g) or three (for XX16g) 2.2-lb. counterweights onto each counterweight mounting bolt for proper tube balance.



**Figure 21** The clamping knobs on the ends of the truss pole assemblies thread into the holes in the lower truss support ring on the lower tube section.

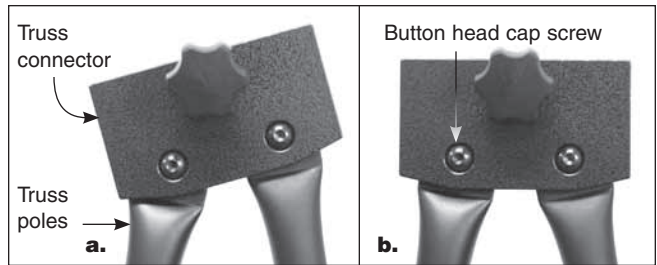




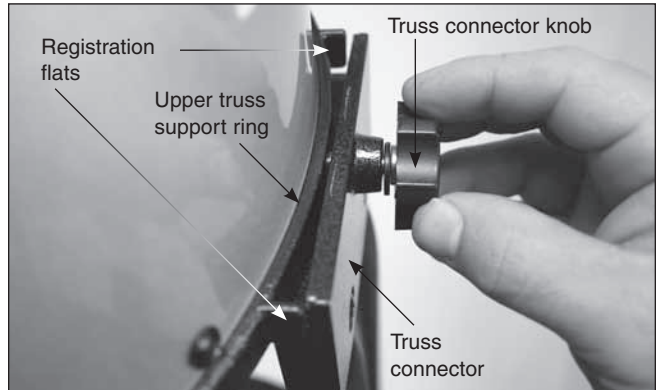
**Figure 22.** The upper tube section should be oriented relative to the lower tube section as shown. Note the orientation of the focuser on the upper tube section relative to the side bearing on the lower tube section.

port ring on the lower optical tube section (**Figure 21**). This is done by simply threading the knobs into the holes in the support ring. Do not completely tighten the knobs just yet.

6. Attach the upper tube section to the four truss connectors at the top of the poles. Orient the upper tube section as shown in **Figure 22**. Hold the upper tube section with one hand while threading the knobs in the truss connectors into the holes in the upper truss support ring. If necessary, you can slightly adjust the position of the truss connector with respect to the pole ends in order to have



**Figure 23.** The position of the truss connectors relative to the pole ends can be adjusted to register the truss connectors with the upper truss support ring.



**Figure 24.** When the truss clamping knob is tightened, it will clamp the truss connector against the registration flats on the upper truss support ring.

the knobs and holes line up (**Figure 23**). When tightened, the knob will clamp the truss connector against the registration flats on the upper truss support ring (**Figure 24**). Repeat this for the other three truss connectors. Firmly tighten the knobs.

7. Now go back and firmly tighten the eight clamping knobs on the lower truss support ring.

If, after assembling, the truss poles are loose within the truss connectors, use the supplied 4mm hex key to tighten the button head cap screws that connect the poles to the truss connectors (see **Figure 23**). This should rarely need to be done.

The telescope is now assembled.

## Accessory Installation

Now that the base is assembled and the optical tube assembled and mounted, all that remains is to attach the EZ Finder II reflex sight and pop an eyepiece into the focuser.

### EZ Finder II

Using the included dovetail mounting bracket, the EZ Finder II will slip neatly into the dovetail base pre-installed on the upper tube section adjacent to the focuser. Just slide the dovetail mounting bracket into the telescope's dovetail mounting base and tighten the thumbscrew on the base to secure the mounting bracket. Make sure the sight tube of the EZ Finder II is *forward* (closest to front opening of telescope).

### Operating the EZ Finder II

Before installing the EZ Finder II on the telescope, you'll need to insert the included 3-volt lithium battery.

1. Insert a small, flat-blade screwdriver into the notch in the battery casing and gently pry it off (**Figure 26**).
2. Slide the CR2032 3V lithium battery under the retaining clip with the positive (+) side facing down (touching the clip).
3. Then press the battery casing back on.

Should the battery die, replacement CR2032 batteries are available at many stores where small batteries are sold.

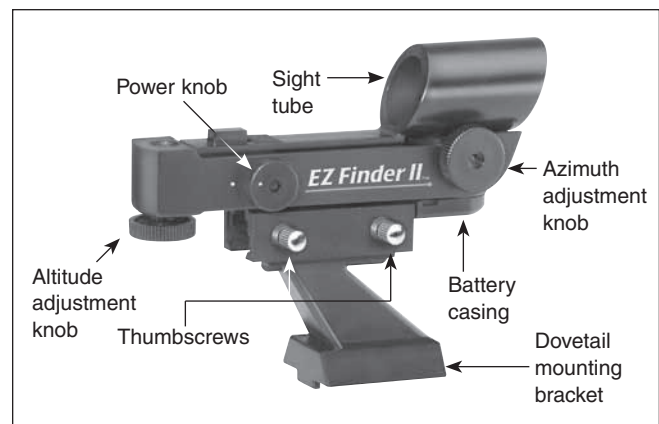
The EZ Finder II works by projecting a tiny red dot (it is not a laser beam) onto a lens mounted in the front of the unit. When you look through the EZ Finder II, the red dot will appear to float in space, helping you to pinpoint your target object (**Figure 25**). The red dot is produced by a light-emitting diode (LED) near the rear of the sight. Turn the power knob (see **Figure 26**) clockwise until you hear the "click" indicating that power has been turned on. Look through the back of the reflex sight with both eyes open to see the red dot. Position your eye at a comfortable distance from the back of the sight. In daylight you may need to cover the front of the sight with your hand to be able to see the dot, which is purposefully quite dim. The intensity of the dot is adjusted by turning the power knob. For best results when stargazing, use the dimmest possible setting that allows you to see the dot without difficulty. Typically a dimmer setting is used under dark skies and a brighter setting is needed under light-polluted skies or in daylight.

### Aligning the EZ Finder II

When the EZ Finder II is properly aligned with the telescope, an object that is centered on the EZ Finder II's red dot should also appear in the center of the field of view of the telescope's eyepiece. Alignment of the EZ Finder II is easiest during daylight, before observing at night. Aim the telescope at a distant object such as a telephone pole or roof chimney and center it in the telescope's eyepiece. The object should be at least 1/4 mile away. Now, with the EZ Finder II turned on, look through it. The object should appear in the field of view. Without moving the main telescope, use the EZ Finder II's azimuth (left/right)



**Figure 25.** The EZ Finder II superimposes a tiny red dot on the sky, showing right where the telescope is aimed.

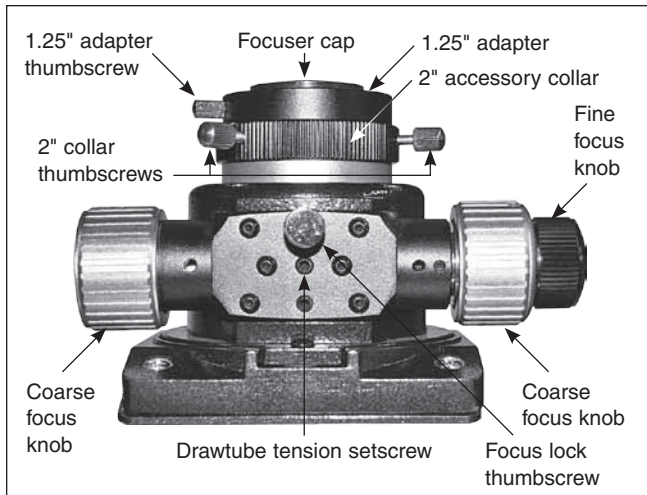


**Figure 26.** The EZ Finder II reflex sight.

and altitude (up/down) adjustment knobs (see **Figure 26**) to position the red dot on the object in the eyepiece. When the red dot is centered on the distant object, check to make sure that the object is still centered in the telescope's field of view. If not, re-center it and adjust the EZ Finder II's alignment again. When the object is centered in the eyepiece and on the EZ Finder's red dot, the EZ Finder II is properly aligned with the telescope. Once aligned, the EZ Finder II will usually hold its alignment even after being removed and remounted. Otherwise, only minimal realignment will be needed. At the end of your observing session, be sure to turn the power knob to the Off position.

### Using Eyepieces

The final step in the assembly process is to insert an eyepiece into the telescope's focuser. First, take the cover cap off the focuser drawtube. To use the 2" DeepView eyepiece, loosen the two thumbscrews on the 2" accessory collar (on the end of the focuser drawtube) and remove the 1.25" adapter. Then place the 2" eyepiece directly into the 2" accessory collar and secure it with the two thumbscrews loosened previously (**Figure 27**). If you cannot achieve focus, you may need to install the included 2" extension adapter on the focuser, then insert the eyepiece into it. The other eyepiece and 1.25"



**Figure 27.** Detail of the dual-speed focuser.

adapter can be placed in the eyepiece rack until they are needed.

To install the 1.25" Illuminated Plössl eyepiece instead of the 2" DeepView eyepiece, keep the 1.25" adapter in the focuser, and make sure the two thumbscrews on the 2" collar are tightened. Now, loosen the thumbscrew on the 1.25" adapter, do not loosen the two thumbscrews on the 2" collar. Insert the 1.25" eyepiece into the 1.25" eyepiece adapter, and secure it by retightening the thumbscrew on the 1.25" eyepiece adapter (**Figure 27**). The other eyepiece can be placed in the eyepiece rack until it is needed.

The basic assembly of your SkyQuest XXg Dobsonian is now complete. It should appear as shown in **Figure 1**. Keep the dust cap in place on the bottom tube section when the telescope is not in use, to minimize the accumulation of dust on the primary mirror. It is also a good idea to store eyepieces in an eyepiece case and to replace the cover cap on the focuser when the telescope is idle.

### Tips for Transporting Your XXg

The SkyQuest XXg Dobsonians are big scopes, but they were designed with portability in mind. For all three telescopes, the optical tube *and* the GoTo base break down *without tools* into manageable components for transporting to and from your favorite observing site in a standard-sized vehicle, or for more convenient storage in your home or garage.

A fit individual should have no trouble setting up, dismantling, or carrying the individual components of an XXg Dobsonian short distances without assistance. Of course, having a helper will facilitate these activities, but if or when you find yourself on your own for an evening observing session, you should be just fine! The larger XX16g could be more of a challenge for one person, especially if you are of slight build. Its heaviest component, the groundplate assembly, weighs 61 lbs., so keep that in mind. The good news is that the groundplate assembly can be rolled on its edge like a big wheel! But lifting

it to get it into and out of a car requires some muscle if you're doing it by yourself. With a helper, however, it should be no problem.

For the XX16g, an optional transport solution is available that allows the telescope to be rolled while fully assembled. Featuring 10" pneumatic tires, this transport solution is particularly useful for moving the telescope from, say, a garage out onto the driveway or into the backyard observing spot. It obviates the need to disassemble the telescope just to move it a short distance! Visit [OrionTelescopes.com](http://OrionTelescopes.com) or call Orion customer service at 800-676-1343 for details.

The optical tube disassembles into a small front tube section including the secondary mirror and focuser, rear tube section housing the primary mirror cell, and four truss-pole pairs. We recommend dismantling the optical tube in reverse order from the way it was assembled. That is, remove the upper tube section first, then the truss tube assemblies, then the counterweights, and finally, remove the lower tube section from the base.

The base disassembles into four separate components: the groundplate assembly (top and bottom groundplates with azimuth motor and encoders installed), left side panel (with altitude motor and encoders installed), right side panel, and front panel. All the hardware has hand knobs for tool-free manipulation and is captive so that nothing will drop off and get dirty or lost in the dark.

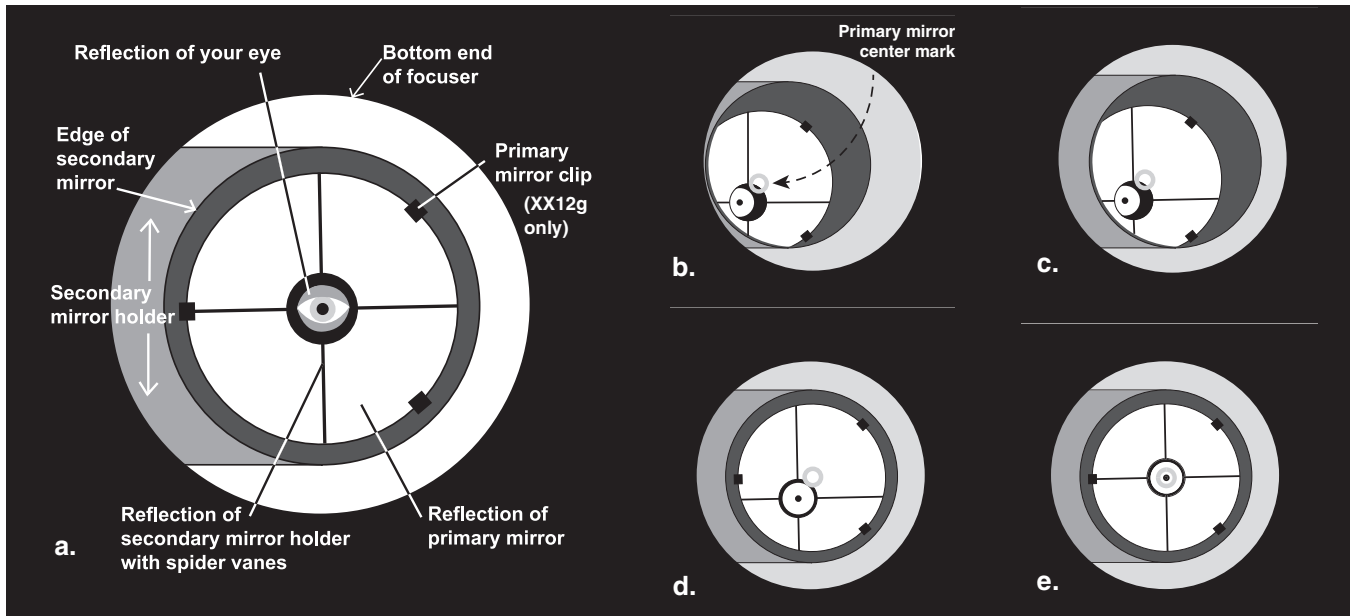
Before transporting the telescope, remove the EZ Finder II (with bracket) and any eyepiece from the focuser. The eyepiece rack can also be removed from the base, if you wish. This will prevent these accessories from getting damaged during transport. These items can be placed in an optional accessory case.

If possible, transport the bottom tube section containing the primary mirror in an upright position, i.e., with the rear end ring resting on the ground. Doing so will reduce stress on the mirror support system. We recommend transporting the tube assembly in the optional padded case set for proper protection.

Each time you assemble the optical tube for an observing session, you should check the optical collimation. It may not need any adjustment, but it could require a minor tweak to dial it in precisely. See the section on collimation for details on how to collimate the optics.

## 3. The GoTo Hand Controller

SkyQuest XXg telescopes feature the SynScan hand controller, which contains an extensive database of stars, deep-sky objects, and solar system denizens – nearly 43,000 in all. The features and functionality of the SynScan controller are covered in detail in a separate manual entitled *SynScan GoTo Hand Controller*. Please refer to that manual before beginning your explorations with the SkyQuest XXg.



**Figure 28.** Collimating the optics. **(a)** When the mirrors are properly aligned, the view down the focuser drawtube should look like this. **(b)** With the collimation cap in place, if the optics are out of alignment, the view might look something like this. **(c)** Here, the secondary mirror is centered under the focuser, but it needs to be adjusted (tilted) so that the entire primary mirror is visible. **(d)** The secondary mirror is correctly aligned, but the primary mirror still needs adjustment. When the primary mirror is correctly aligned, the “dot” will be centered, as in **(e)**.

## 4. Collimating the Optical System

To get the sharpest images, your telescope’s optical system must be in precise alignment. The process of aligning the primary and secondary mirrors with each other and with the mechanical axis of the telescope is called collimating. Collimating is relatively easy to do and can be done in daylight or at night.

Because the primary mirror is shipped separately from the optical tube, the telescope’s optics must be collimated before it can be used. Most of the adjustments will be to the tilt of the primary mirror, as the secondary mirror has been pre-aligned at the factory. It is also good idea to check the collimation (optical alignment) of your telescope before each observing session and make any necessary adjustments.

To check collimation, remove the eyepiece and look down the focuser drawtube. You should see the secondary mirror centered in the drawtube, as well as the reflection of the primary mirror centered in the secondary mirror, and the reflection of the secondary mirror (and your eye) centered in the reflection of the primary mirror, as depicted in **Figure 28a**. If anything is off-center, as in **Figure 28b**, proceed with the following collimation procedure.

### The Collimation Cap and Mirror Center Mark

Your XXg comes with a collimation cap. This is a simple cap that fits on the focuser drawtube like a dust cap, but has a hole in the center and a reflective inner surface. The cap helps center your eye so that collimating is easier to perform. **Figures 28b-e** assume you have the collimation cap in place.

As an additional aid in collimating, the primary mirror of the XXg has a tiny adhesive ring marking its exact center (Figure 3a). This center ring will not affect the images you see when observing with the telescope in any way (since it lies directly in the shadow of the secondary mirror), but it will greatly facilitate collimating when using the supplied collimation cap or other, more sophisticated collimation devices, such as the Orion LaserMate Deluxe II laser collimator.

### Preparing the Telescope for Collimating

Once you get the hang of collimating, you will be able to do it quickly even in the dark. For now, it is best to collimate in daylight, preferably in a brightly lit room and aimed at a white wall. It is recommended that the telescope tube be oriented horizontally. This will prevent any parts from the secondary mirror from falling down onto the primary mirror and causing damage if something comes loose when you are making adjustments. Place a sheet of white paper inside the optical tube directly opposite the focuser. This will provide a bright “background” when viewing into the focuser. When properly set up for collimation, your telescope should resemble **Figure 29**.



### Aligning the Secondary Mirror

With the collimation cap in place, look through the hole in the cap at the secondary (diagonal) mirror. Ignore the reflections for the time being. The secondary mirror itself should be centered in the focuser drawtube. If it isn't, as in **Figure 28b**, its position must be adjusted. This positional adjustment of the secondary mirror will rarely, if ever, need to be done.

To adjust the secondary mirror left-to-right in the focuser drawtube, use the included 2mm hex key to loosen the three small alignment setscrews in the center hub of the 4-vaned spider several turns. Now, grasp the mirror to prevent it from rotating (be careful not to touch the surface of the mirror), while turning the center screw with a Phillips screwdriver (**Figure 30**). Turning the screw clockwise will move the secondary mirror toward the front opening of the optical tube, while turning the screw counter-clockwise will move the secondary mirror toward the primary mirror. When the secondary mirror is centered left-to-right in the focuser drawtube, rotate the secondary mirror holder until the reflection of the primary mirror is as centered in the secondary mirror as possible. It may not be perfectly centered, but that is OK for now. Tighten the three small alignment setscrews equally to secure the secondary mirror in that position.

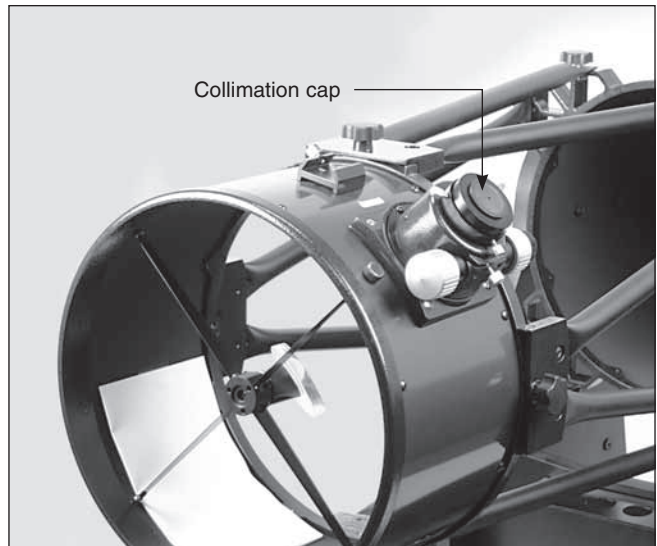
**Note:** When making these adjustments, be careful not to stress the spider vanes or they may bend.

The secondary mirror should now be centered in the focuser drawtube. Now we will shift our attention to the reflections within the secondary mirror in order to properly adjust the tilt of the secondary mirror. Adjusting the tilt of the secondary mirror and the tilt of the primary mirror are the two collimation adjustments that will be done most often.

If the entire primary mirror reflection is not visible in the secondary mirror, as in **Figure 28c**, you will need to adjust the tilt of the secondary mirror. This is done by alternately loosening one of the three secondary mirror alignment setscrews while tightening the other two (**Figure 31**). Do not make excessive turns of these setscrews or force them past their normal travel. A simple 1/2 turn of the screw can dramatically change the tilt of the secondary mirror. The goal is to center the primary mirror reflection in the secondary mirror, as in **Figure 28d**. Don't worry that the reflection of the secondary mirror (the smallest circle, with the collimation cap "dot" in the center) is off-center. You will fix that in the next step.

### Aligning the Primary Mirror

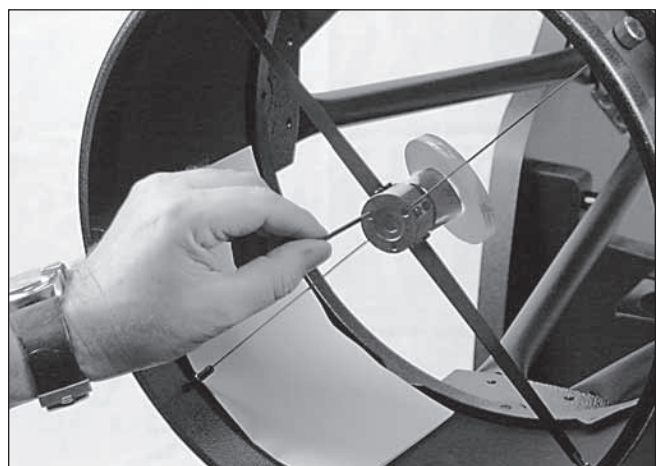
The final adjustment is made to the tilt of the primary mirror. It will need adjustment if, as in **Figure 28d**, the secondary mirror is centered under the focuser and the reflection of the primary mirror is centered in the secondary mirror, but the small reflection of the secondary mirror (with the "dot" of the collimation cap) is off-center.



**Figure 29.** The SkyQuest optical tube properly set up for collimation.



**Figure 30.** To center the secondary mirror under the focuser, hold the mirror holder in place with one hand while adjusting the center bolt with a Phillips screwdriver. Do not touch the mirror's surface!



**Figure 31.** Adjust the tilt of the secondary mirror by adjusting one or more of the three alignment setscrews with a 2mm hex key.

The tilt of the primary mirror is adjusted with the three large spring-loaded collimation knobs on the rear end of the optical tube (**Figure 32**). The three smaller thumbscrews lock the mirror's position in place. These thumbscrews must be loosened before any collimation adjustments can be made to the primary mirror.

To start, turn the smaller thumbscrews counterclockwise a few turns each. Use a screwdriver in the slots, if necessary.

Now, try tightening or loosening one of the collimation knobs. Look into the focuser and see if the secondary mirror reflection has moved closer to the center of the primary mirror. You can easily determine this with the collimation cap and mirror center mark by simply watching to see if the "dot" of the collimation cap is moving closer or further away from the "ring" on the center of the primary mirror. If turning the one knob does not seem to bring the dot closer to the ring, try using one of the other collimation knobs. It will take some trial-and-error using all three knobs to properly align the primary mirror. Over time you will get the feel for which collimation screws to turn to move the image in a given direction.

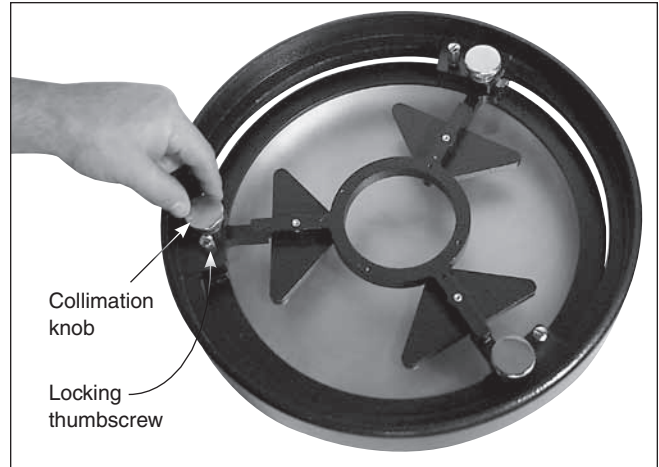
When you have the dot centered as much as is possible in the ring, your primary mirror is collimated. The view through the collimation cap should resemble **Figure 28e**. Re-tighten the locking thumbscrews in the bottom of the mirror cell.

A simple star test will tell you whether the optics are accurately collimated.

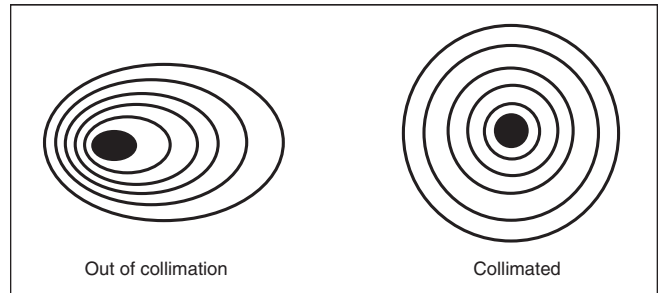
### Star-Testing the Telescope

When it is dark, point the telescope at a bright star high in the sky and center it in the eyepiece's field of view. Slowly defocus the image with the focusing knob. If the telescope is correctly collimated, the expanding disk should be a perfect circle (**Figure 33**). If the image is unsymmetrical, the telescope is out of collimation. The dark shadow cast by the secondary mirror should appear in the very center of the out-of-focus circle, like the hole in a doughnut. If the "hole" appears off center, the telescope is out of collimation.

If you try the star test and the bright star you have selected is not accurately centered in the eyepiece, then the optics will always appear out of collimation, even though they may be perfectly aligned. It is critical to keep the star centered, so over time you will need to make slight corrections to the telescope's position in order to account for the sky's apparent motion.



**Figure 32.** The tilt of the primary mirror is adjusted by turning one or more of the three larger thumbscrews. (XX12g shown)

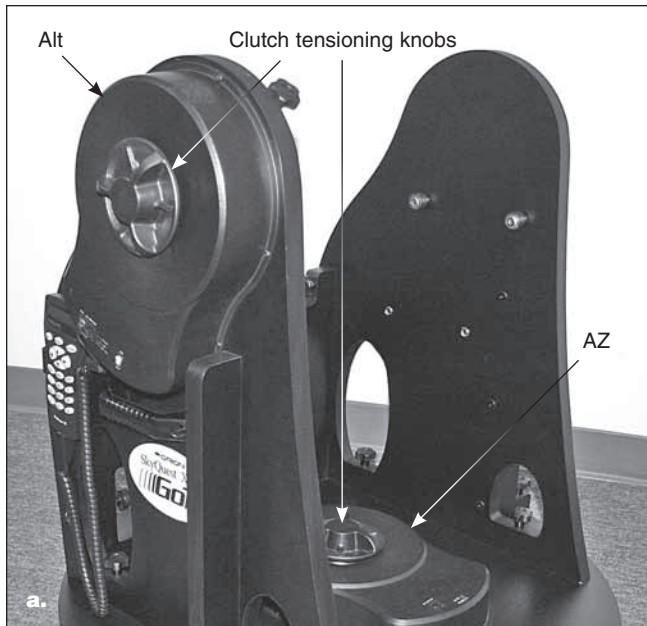


**Figure 33.** A star test will determine if a telescope's optics are properly collimated. An unfocused view of a bright star through the eyepiece should appear as illustrated on the right if the optics are perfectly collimated. If the circle is unsymmetrical, as in the illustration on the left, the scope needs collimation.

## 5. Using Your Telescope

### Using the Clutch Tensioning Knobs

The XXg Dobs all now feature large clutch tensioning knobs on both the altitude and azimuth axes. Located on the altitude and azimuth motor/encoder housings (**Figure 34**), these knobs allow the user to adjust the amount of tension (friction) in both the altitude and azimuth motion for moving the telescope by hand. Rotating the knob clockwise increases the tension, while turning it counterclockwise decreases the tension. The closed-loop encoder system of the XXg Dobs allows the scope to be moved manually without losing the initial GoTo star alignment. The clutch knobs allow you to set the amount of motion tension on each axis independently to the level you desire for smooth manual slewing of the telescope.



**Figure 34. a)** The redesigned altitude (Alt) and (AZ) azimuth motor/encoder housings of the XXg Dobs feature large manual clutch knobs for adjustable motion tension. **b)** Rotate the clutch knob to adjust the friction of motion for slewing the telescope by hand.

If a clutch tension it is set too loose, the scope may not slew on that axis, or may slew intermittently. In that case you should tighten the clutch knob(s) a little until a normal slewing motion is achieved. If you add significant weight to the front of the telescope, such as a heavy eyepiece and finder scope or a full-aperture glass solar filter, the scope could become “front heavy.” In that case you may have to tighten the altitude clutch knob some so that the tube doesn’t slip when moving in the up/down direction.

### Focusing the Telescope

The SkyQuest XXg Dobsonians come standard with a 2" dual-speed (11:1) Crayford focuser (**Figure 27**). The focuser has coarse focus knobs and a fine focus (11:1) knob for very precise focusing. The focuser allows use of 2" or 1.25" eyepieces and the Crayford design prevents image shift while focusing.

To focus, with an eyepiece in the focuser and secured with the thumbscrews, move the telescope so the front end is pointing in the general direction of an object at least 1/4-mile away. Now, with your fingers, slowly rotate one of the coarse focus knobs until the object comes into sharp focus. Go a little bit beyond sharp focus until the image just starts to blur again, then reverse the rotation of the knob, just to make sure you’re close to the focus point.

Now, use the fine focus knob to achieve precise focus. Eleven turns of the fine focus knob are equivalent to one turn of the coarse focus knobs, so much finer adjustment is possible than with just the coarse focus knobs alone. You’ll find this is a great convenience, especially when attempting to focus at high magnifications. If you have trouble focusing, rotate the coarse focusing knob so the drawtube is inward as far as it will go. Now look through the eyepiece while slowly rotating the focusing knob in the opposite direction. You should soon see the point at which focus is reached. The thumbscrew on the bottom of the focuser body (**Figure 27**) will lock the focuser drawtube in place, if desired. This is usually not necessary, however. Before focusing, remember to first loosen this thumbscrew.

If you find the drawtube tension when focusing is either too tight (i.e., focus knob is difficult to turn) or too loose (i.e., drawtube moves by itself under the weight of the eyepiece), you can adjust it by tightening or loosening the drawtube tensioning setscrew on the focuser, which is located just below the focus lock thumbscrew (see **Figure 27**). Adjust this setscrew with the included 2.5mm hex key. Do not loosen the setscrew too much as there must be some tension to keep the drawtube secure within the focuser. The other setscrew below the drawtube tensioning setscrew does not affect drawtube tension and should not be adjusted.



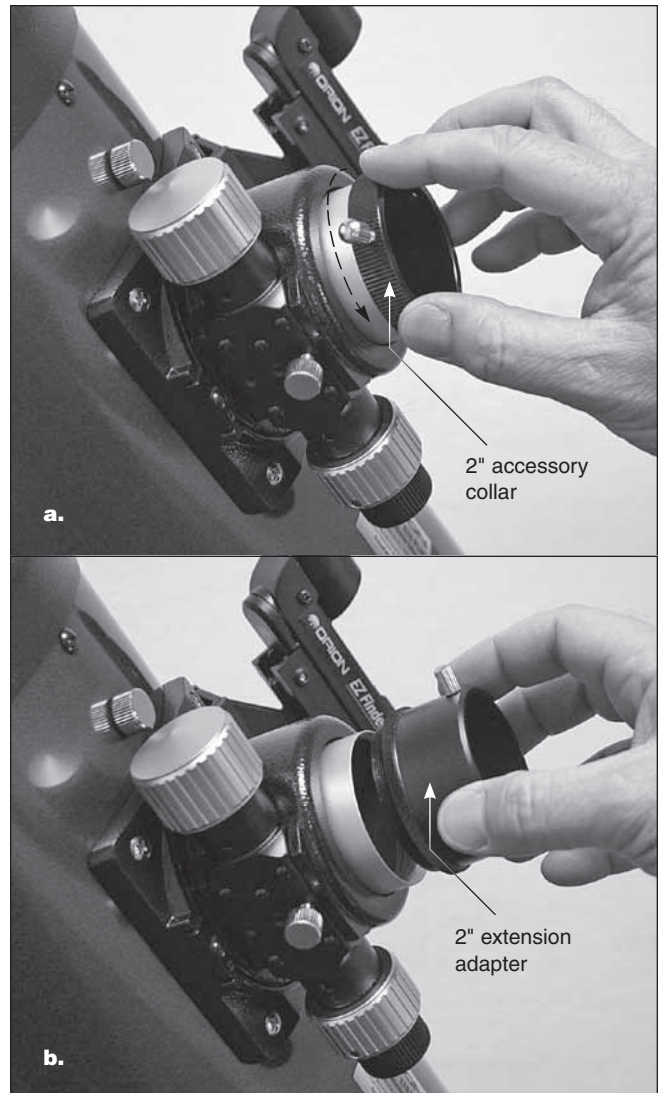
If an image does not come into focus with a particular eyepiece because you run out of outward focus travel, you may need to use the included 2" extension adapter. This adapter threads onto the focuser drawtube. First, you'll need to remove the 2" accessory collar from the drawtube by unthreading it (**Figure 35a**). Then thread the 2" extension adapter into the drawtube (**Figure 35b**). Insert a 2" eyepiece into the extension adapter and secure it with the two thumbscrews. Or, to use 1.25" eyepiece with the extension adapter, insert and secure the 1.25" adapter in the extension adapter, then insert the eyepiece into the 1.25" adapter.

### Viewing with Eyeglasses

If you wear eyeglasses, you may be able to keep them on while you observe, if your eyepieces have enough eye relief to allow you to see the whole field of view. You can try this by looking through the eyepiece first with your glasses on and then with them off, and see if the glasses restrict the view to only a portion of the full field. If they do, you can easily observe with your glasses off by just refocusing the telescope as needed. If you suffer from severe astigmatism, however, you may find images noticeably sharper with your glasses on.

### Magnification

Magnification, or power, is determined by the focal length of the telescope and the focal length of the eyepiece. Therefore, by using eyepieces of different focal lengths, the resultant magnification can be varied.



**Figure 35. (a)** Removing the 2" accessory collar, **(b)** Thread the 2" extension adapter into the focuser drawtube.



---

Magnification is calculated as follows:

$$\frac{\text{Telescope Focal Length (mm)}}{\text{Eyepiece Focal Length (mm)}} = \text{Magnification}$$

The XX12g, for example, has a focal length of 1500mm. So, the magnification with the supplied 28mm 2" eyepiece is:

$$\frac{1500\text{mm}}{28\text{mm}} = 54\text{x}$$

The magnification provided by the 12.5mm illuminated eyepiece is:

$$\frac{1500\text{mm}}{12.5\text{mm}} = 120\text{x}$$

The maximum attainable magnification for a telescope is directly related to how much light its optics can collect. A telescope with more light-collecting area, or aperture, can yield higher magnifications than a smaller-aperture telescope. The maximum practical magnification for any telescope, regardless of optical design, is about 50x per inch of aperture. This translates to about 600x for the XX12g. Of course, such high magnification will only yield acceptable images if atmospheric conditions are extremely favorable.

More typically, useful magnifications will be limited to 200x or less, regardless of aperture. This is because the Earth's atmosphere distorts light as it passes through. On nights of good "seeing," the atmosphere will be still and will yield the least amount of distortion. On nights of poor seeing, the atmo-

sphere will be turbulent, which means different densities of air are rapidly mixing. This causes significant distortion of the incoming light, which prevents sharp views at high magnifications.

Keep in mind that as magnification is increased, the brightness of the object being viewed will decrease; this is an inherent principle of the physics of optics and cannot be avoided. If magnification is doubled, an image appears four times dimmer. If magnification is tripled, image brightness is reduced by a factor of nine!

The SkyQuest XXg Dobs are designed to accept eyepieces with a barrel diameter of either 1.25" or 2". At low magnifications, 2" eyepieces can provide a wider field of view than standard 1.25" eyepieces. A wider field can be desirable for viewing extended deep-sky objects that are too large to fit within a narrower field of view.

### **Using a Light Shroud**

We highly recommend using a light shroud over the open truss tube portion of the optical tube assembly when observing. Usually made of breathable, stretchy, opaque black fabric, a shroud blocks stray light from entering the optical path at oblique angles, thus improving image contrast. Use of the shroud will also lessen the accumulation of dust and dirt on the mirrors during use, and will help prevent dew from forming on them. A custom-designed light shroud is available for each of the SkyQuest XXg Dobsonians from Orion.

---

## 6. Specifications

### SkyQuest XX12g GoTo

Primary mirror	305mm diameter, parabolic, center-marked
Focal length	1500mm
Focal ratio	f/4.9
Focuser	Dual-speed Crayford (11:1), accepts 2" and 1.25" eyepieces with included adapter
Optical tube material	Rolled steel
Azimuth bearing	Thrust needle bearing
Altitude bearing	Ball bearing
Eyepieces	28mm DeepView, 2" barrel; 12.5mm Illuminated Plössl, 1.25" barrel
Eyepiece magnifications	54x and 120x
Finder scope	EZ Finder II Reflex Sight
Eyepiece rack	Holds three 1.25" eyepieces and one 2" eyepiece
Mirror coatings	Enhanced aluminum (94% reflectivity) with SiO <sub>2</sub> overcoat
Minor axis of secondary mirror	70mm
Optical tube weight (assembled)	47 lbs.
Base weight	89 lbs.
Tube length	58.3"
Operation	Northern or Southern hemisphere
Power requirement	12V DC 2.1 Amp (tip positive)
Motor type	DC servo with optical encoders for altitude and azimuth axes
Slew speeds	Rate 0 = 1.0X Rate 1 = 2X Rate 2 = 16X Rate 3 = 32X Rate 4 = 50X Rate 5 = 200X Rate 6 = 400X Rate 7 = 600X Rate 8 = 800X Rate 9 = 1000X
Tracking rates	Sidereal (default), Lunar, Solar.
Alignment method	Brightest Star, Two Star
Database	Over 42,900 objects including: Complete Messier & Caldwell catalogs, 7840 NGC objects, 5386 IC objects, 29523 SAO stars, 8 planets, Moon, 212 named stars, 55 well-known double stars, 20 well-known variable stars, 25 user-defined objects.

### SkyQuest XX14g GoTo

Primary mirror	356mm diameter, parabolic, center-marked
Focal length	1650mm
Focal ratio	f/4.6
Focuser	Dual-speed Crayford (11:1), accepts 2" and 1.25" eyepieces with included adapter
Optical tube material	Rolled steel
Azimuth bearing	Thrust needle bearing
Altitude bearing	Ball bearing
Eyepieces	28mm DeepView, 2" barrel; 12.5mm Illuminated Plössl, 1.25" barrel
Eyepiece magnifications	59x and 132x
Finder scope	EZ Finder II Reflex Sight
Eyepiece rack	Holds three 1.25" eyepieces and one 2" eyepiece
Mirror coatings	Enhanced aluminum (94% reflectivity) with SiO <sub>2</sub> overcoat
Minor axis of secondary mirror	80mm
Optical tube weight (assembled)	64 lbs.
Base weight	94 lbs.
Tube length	61"
Operation	Northern or Southern hemisphere
Power requirement	12V DC 2.1 Amp (tip positive)
Motor type	DC servo with optical encoders for altitude and azimuth axes
Slew speeds	Rate 0 = 1.0X Rate 1 = 2X Rate 2 = 16X Rate 3 = 32X Rate 4 = 50X Rate 5 = 200X Rate 6 = 400X Rate 7 = 600X Rate 8 = 800X Rate 9 = 1000X
Tracking rates	Sidereal (default), Lunar, Solar.
Alignment method	Brightest Star, Two-Star
Database	Over 42,900 objects including: Complete Messier & Caldwell catalogs, 7840 NGC objects, 5386 IC objects, 29523 SAO stars, 8 planets, Moon, 212 named stars, 55 well-known double stars, 20 well-known variable stars, 25 user-defined objects.

---

## SkyQuest XX16g GoTo

Primary mirror	406mm diameter, parabolic, center-marked
Focal length	1800mm
Focal ratio	f/4.4
Focuser	Dual-speed Crayford (11:1), accepts 2" and 1.25" eyepieces with included adapter
Optical tube material	Rolled steel
Azimuth bearing	Thrust needle bearing
Altitude bearing	Ball bearing
Eyepieces	28mm DeepView, 2" barrel; 12.5mm Illuminated Plössl, 1.25" barrel
Eyepiece magnifications	64x and 144x
Finder scope	EZ Finder II Reflex Sight
Eyepiece rack	Holds three 1.25" eyepieces and one 2" eyepiece
Mirror coatings	Enhanced aluminum (94% reflectivity) with SiO <sub>2</sub> overcoat
Minor axis of secondary mirror	91mm
Optical tube weight (assembled)	69 lbs.
Base weight	105 lbs.
Tube length	68"
Operation	Northern or Southern hemisphere
Power requirement	12V DC 2.1 Amp (tip positive)
Motor type	DC servo with optical encoders for altitude and azimuth axes
Slew speeds	Rate 0 = 1.0X Rate 1 = 2X Rate 2 = 16X Rate 3 = 32X Rate 4 = 50X Rate 5 = 200X Rate 6 = 400X Rate 7 = 600X Rate 8 = 800X Rate 9 = 1000X
Tracking rates	Sidereal (default), Lunar, Solar.
Alignment method	Brightest Star, Two-Star
Database	Over 42,900 objects including: Complete Messier & Caldwell catalogs, 7840 NGC objects, 5386 IC objects, 29523 SAO stars, 8 planets, Moon, 212 named stars, 55 well-known double stars, 20 well-known variable stars, 25 user-defined objects.

---

## **One-Year Limited Warranty**

This Orion product is warranted against defects in materials or workmanship for a period of one year from the date of purchase. This warranty is for the benefit of the original retail purchaser only. During this warranty period Orion Telescopes & Binoculars will repair or replace, at Orion's option, any warranted instrument that proves to be defective, provided it is returned postage paid. Proof of purchase (such as a copy of the original receipt) is required. This warranty is only valid in the country of purchase.

This warranty does not apply if, in Orion's judgment, the instrument has been abused, mishandled, or modified, nor does it apply to normal wear and tear. This warranty gives you specific legal rights. It is not intended to remove or restrict your other legal rights under applicable local consumer law; your state or national statutory consumer rights governing the sale of consumer goods remain fully applicable.

For further warranty information, please visit [www.OrionTelescopes.com/warranty](http://www.OrionTelescopes.com/warranty).

Orion Telescopes & Binoculars  
Corporate Offices: 89 Hangar Way, Watsonville CA 95076 - USA  
Customer Support: [www.OrionTelescopes.com/contactus](http://www.OrionTelescopes.com/contactus)

© Copyright 2013 Orion Telescopes & Binoculars

---