

ZEISS Primovert

Examine and Assess your Living Cells – Quickly and Easily.

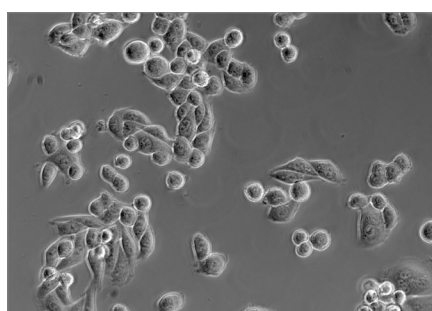

HeLa cells, phase contrast, magnification: 20x

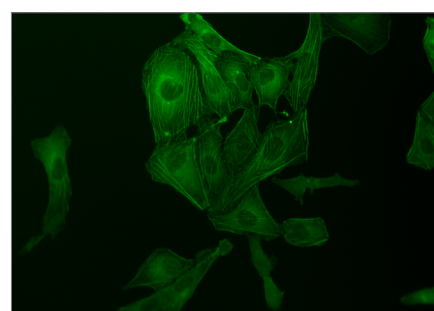

U2OS cells, GFP stained, fluorescence contrast, magnification: 20x

Inspect and evaluate the morphology and development of living cells. With your Primovert you examine unstained cells in phase contrast and GFP-labeled cells in fluorescence contrast quickly and efficiently. The inverted microscope is especially perfect for your cell culture lab. Primovert is compact, you place it right inside your cell culture hood.

Bring the flexibility in your cell culture laboratory: with Primovert HDcam and the iPad imaging app Labscope you observe and discuss cells independently from the sterile workplace together with colleagues. Snap microscope images, annotate and create reports, and share them easily wirelessly with others.

Highlights

- Switch from phase contrast to fluorescence contrast to assess both undyed and GFP-labeled cells.
- The inverted microscope is compact and fits directly in your Laminar Flow Box – you work directly in the sterile environment.
- Your Primovert is immediately ready for use. You reactivate the microscope in stand-by mode directly at the table. Primovert switches in walk-away mode automatically after 15 minutes off.
- Primovert HDcam integrates a camera. Use your iPad and the free iPad imaging app Labscope and discuss the monitor image together in the team.

Your Phase Contrast Microscope

Primovert has a universal phase slider for all objective lenses – you use a single phase ring Ph1 for 10x, 20x, and 40x magnification, eliminating the need to adjust the phase position when changing the magnification level.

Ergonomic Work

With Primovert ergo and the ergotube, which allows you to adjust the viewing angle, you can work comfortably either standing or sitting.



ZEISS Primovert

Examine and Assess your Living Cells – Quickly and Easily.

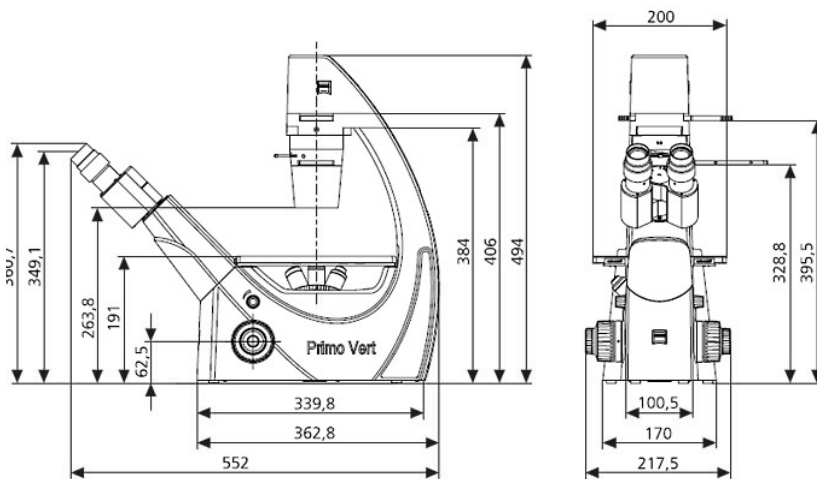

Main Applications for Primovert:

- Sterility checks
- Cell checks – protein, DNA or RNA preparation and screenings after donations (pharmacology)
- Differentiation of cell types
- Characterization of cell lines (oncology)
- Growing of cells to produce artificial tissues or organs

Optional Accessories:

- Object guide
- Mounting frames for Petri dishes, etc.
- Stage inserts (metal or glass) and stage enlargements
- Cameras and camera adapters
- Eyepiece micrometer and eyepiecepointer
- Neutral density and green
- Interference filters

Norms and Standards Met:

CE, UL, CSA, IVD, DIN EN 61010-1 (IEC 61010-1), ISO 9001

Technical Data

Objectives	Infinity-corrected objective range with W 0.8 mounting thread Plan-Achromat: 4x / 0.1, 4x / 0.1 Ph0, 10x / 0.25 Ph1 LD Plan-Achromat: 20x / 0.3 Ph1, 40x / 0.5 Ph1, 20x / 0.3 Ph2, 40x / 0.5 Ph 2 Manual change via quadruple objective nosepiece
Phase-Slider	Universal phase slider for the objectives Ph1: for Ph2: Higher resolution
Eyepieces	WF 10x/20 Br. foc.
Stage	Fixed, Dimensions 200(w) x 239(d) mm, Right side specimen guide, Coaxial drive
Verniers with numerical and alphabetic scale	X direction: Numerical scale, readable from right to left Y direction: Alphabetic scale, readable in the mirror
Condensers	LD condenser 0.3 for magnifications 4 x to 40x, WD = 72 mm, LD condenser 0.4 for magnifications 4 x to 40x, WD = 55 mm
Trinocular (photo)tube 45°/20	Viewing angle 45°, FOV 20, Photo/video port tube factor 1x, 60 mm mount, Fixed beam splitting 50 % vis / 50 % doc
Acquired visual field of the camera	11.4 mm x 8.56 mm (14.2 mm diagonal)
Fixed built-in camera adapter	0.63x
Output	HDMI / USB2.0 / Ethernet port/ SD card
iPad holder	Tilttable 40-80 degree
Light source	HAL: 6 V, 30 W, LED: White light, 3 W, iLED: blue LED, peak wavelength 470 nm



microscopy@zeiss.com
www.zeiss.com/primovert

